

---

# TEST REPORT

---



A Z U M A  
Design

## POOL FENCE



CLIENT – GLASS HARDWARE AUSTRALIA

PRODUCT – POLARIS SOFT CLOSE HINGE 155 SERIES

TESTED BY

AZUMA DESIGN PTY LTD

AZT0353.20

NATA ACCREDITED LABORATORY NO. 15147

This document shall not be reproduced, except in full

Test results in this report are relevant only to the sample tested

The results of the tests, calibrations and/or measurements included in this document are traceable to Australian/national standards

# 1 Customer Requirements

To test the pool fence sample according to AS1926.1 Set 2012- Swimming Pool Safety Standards Set- Section 3- Loading Requirements. Only the applicable tests for this type of sample shall be carried out.

## 2 Test Sample Information

### 2.1 General Information

<b>Product Name/Number</b>	Polaris Soft Close Hinge 125 Series
<b>Customer</b>	Glass Hardware Australia
<b>Address</b>	Unit 6, 4 Stockyard Place, West Gosford NSW 2250
<b>Azuma Test Number</b>	AZT0353.20
<b>Date of Test</b>	07/09/2020 – 18/09/2020
<b>Sample</b>	Supplied and installed by Customer in good condition
<b>Overall Size</b>	1275 mm (Height) x 2650 mm (Width)
<b>Test Sample Description</b>	Glass gate assembly consisting of three panels of glass. Two side fixed glass panels one with a latching bracket and the other with hinge fixings for two hinges. Hinges have soft closing action and the latch has a magnetic strike and bolt.

### 2.2 Barrier

<b>Material</b>	Toughened Glass	
<b>Overall Dimensions</b>	<b>Hinge Panel</b>	1200 mm (H) x 1000 mm (W) x 12 mm (T)
	<b>Latch Panel</b>	1200 mm (H) x 800 mm (W) x 12 mm (T)
<b>Gap between Vertical Elements (&lt; 100 mm)</b>	N/A	
<b>Gap between Horizontal Elements (&gt; 900 mm)</b>	1275 mm	
<b>Total Product Height Greater than 1100 mm</b>	1275 mm	
<b>Gap between bottom of barrier and finished ground level (&lt; 100 mm)</b>	75 mm	

Azuma Design Pty Ltd

38 Redfern Street Werherill Park, NSW, 2164 Australia +61(02) 9604 0255

Test results in this report are relevant only to the sample tested.

Accreditation Number: 15147 - Accredited for compliance with ISO/IEC 17025 - TESTING

This document shall not be reproduced, except in full.

AZT 0353.20



## 2.3 Gate

Material	Toughened Glass
Overall Dimensions	1200 mm (H) x 800 mm (W) x 8 mm
Gap between Vertical Elements (< 100 mm)	10 mm Latch side 8 mm Hinge side
Gap between Horizontal Elements (> 900 mm)	1275 mm
Total Product Height Greater than 1100 mm	1275 mm
Gap between bottom of barrier and finished ground level (< 100 mm)	75 mm

## 2.4 Spigots (Supplied by Azuma Design)

Material	Duplex 2205 Stainless Steel
Overall Dimensions	50 mm (Width) x 50 mm (Depth) x 160 mm (Height)
Base Plate (if applicable)	100 mm (Width) x 100 mm (Depth) x 8 mm (Thickness)
Drawing Supplied	N/A
Fixing Method	14G x 50 mm Countersunk hex drive screw into timber
Spacing between Posts	220 mm (Left Side) and 700 mm (Right Side)

## 2.5 Hardware

Latch	Polaris Standard Side Pull Latch
Hinge	Polaris 155 Retro-Fit Polaris Soft Close Hinge



Figure 1: Tested Hinge



Figure 2: Tested Latch

### **3 Strength and Rigidity of Barrier Openings**

---

This Test is not applicable to this test sample

---

### **4 Strength of Posts and Footings**

---

This Test is not applicable to this test sample

---

### **5 Strength of Fencing Components**

---

This Test is not applicable to this test sample

---

### **6 Flexible Materials & Components**

---

This Test is not applicable to this test sample

---

### **7 Strength Test for Rigid Components of Gate Units**

---

This Test is not applicable to this test sample

---

## 8 Durability of Gate Units

### 8.1 Procedure

From AS 1926.1 - 2012 - Appendix F - Test of Durability of Gate Units.

1. Install the gate unit in accordance with the manufacturer's instructions on a site which simulates the in situ condition with the gate posts securely anchored into the ground.
2. Ensure that the gate and its latch comply with Clause 2.4.
3. Measure and record the force (to the nearest 5 N) required to release the latch.
4. Release the latch and open the gate to the 90-degree position.
5. Release the gate and allow it to close under the action of the self-closing device.
6. Repeat Steps (d) and (e) for a total of 10 000 operations or until the latch fails to operate, whichever occurs first. The latch shall not be lubricated or adjusted during this test.
7. Inspect the gate to see whether it still complies with Clause 2.4.
8. Measure and record the force (to the nearest 5 N) required to release the latch.
9. Inspect the gate, including the hinges and latch together with the gate posts, for any damage which would affect the ability of the gate to comply with the requirements of Section 2.

### 8.2 Results

<b>Number of Operations the sample completed</b>	26,068 cycles
<b>Does the gate still comply with clause 2.4 after test completed</b>	Yes
<b>The force required to release the latch at the start of the test</b>	10 N
<b>The force required to release the latch at the end of the test</b>	10 N
<b>Any damage to the gate, hinges, latching device or gate posts at the end of the test</b>	Nil
<b>Result</b>	Pass

## 9 Additional Testing for Gate Units

From AS 1926.1 - 2012 - Section 3.4 - Closing and Latching of Gates.

1. The gate shall close and latch from fully open to resting on the latch, under both of the following conditions:
  - a. Under the natural weight of the gate.
  - b. With the gate open and after a weight of 25 kg has been placed on the top rail or component at a point 100 mm from the outer edge of the locking stile of the gate for 30 seconds and then removed.
2. With the gate closed, the latch and posts of the barrier to which the gate is attached shall be capable of retaining the gate in a closed position when 25 kg is placed at the same location and remains on the gate.

Gate Closes under natural weight	Pass
Gate opened and 25 kg placed 100 mm from locking stile	Pass
Gate closed and 25 kg placed 100 mm from locking stile	Pass
Result	Pass



Figure 3: 25 kg Gate Open

Azuma Design Pty Ltd

38 Redfern Street Wetherill Park, NSW, 2164 Australia +61(02) 9604 0255

Test results in this report are relevant only to the sample tested.

Accreditation Number: 15147 - Accredited for compliance with ISO/IEC 17025 - TESTING.

This document shall not be reproduced, except in full.

AZT 0353.20





Figure 4: 25 kg Gate Closed

## 10 Conclusion and Signatories

### 10.1 Conclusion

From the results achieved, it is evident that the sample satisfied the tested requirements as per AS1926.1-2012 Swimming Pool Safety Standards Set.

### 10.2 Signatories

Tested By: Ash Horne

Signature: AHorne

Date: 01/10/2020

**END OF REPORT**



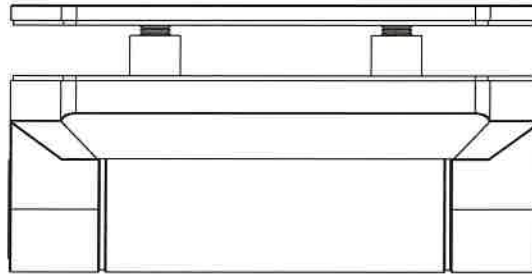
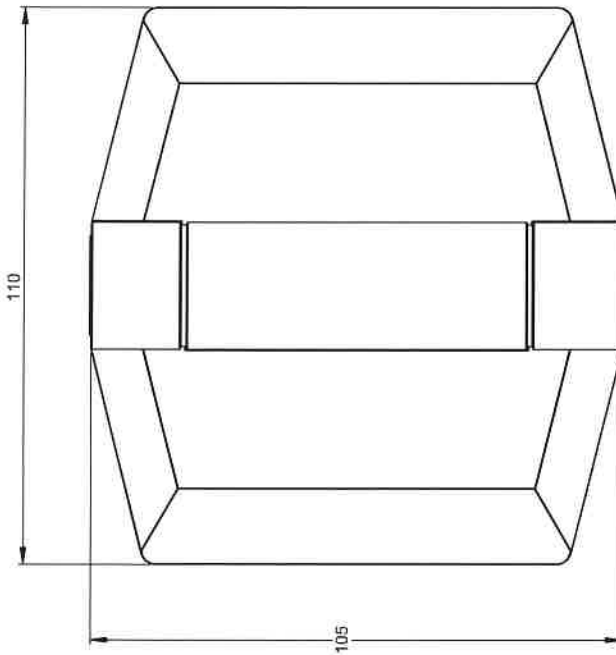
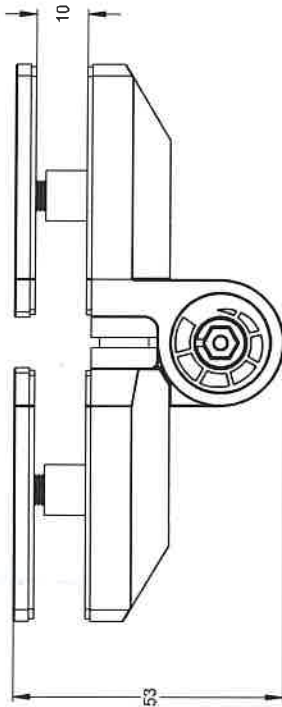
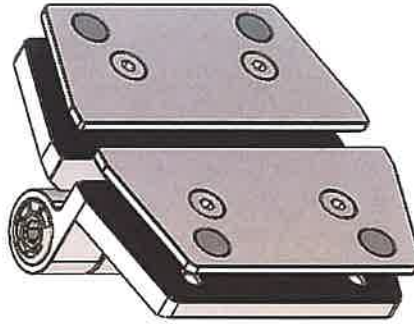
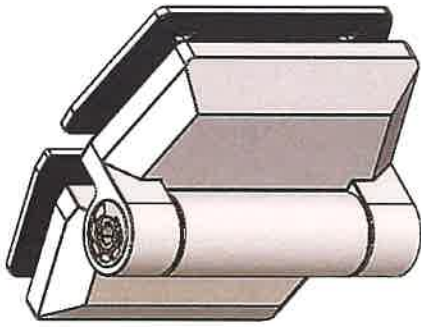

INFORMATION SUPPLIED BY CUSTOMER

PROJECT <b>POLARIS 155 HINGE - GC</b>	TITLE <b>155GG HINGE - GA</b>
	PART NUMBER <b>155GG-001</b>
MATERIAL: <b>SEE PARTS</b>	EST. WEIGHT: <b>822g</b>
FINISH: <b>TBA</b>	SHEET SIZE: <b>A3</b>
SHEET: <b>1 of 2</b> REV: <b>B</b>	
DRAWN BY: <b>CAS</b>	DRAWN DATE: <b>12/06/2020</b>
APPROVED BY:	APPROVED DATE:
THIS DRAWING AND ANY INFORMATION OR DATA CONTAINED HEREIN IS THE CONFIDENTIAL AND THE COPYRIGHT PROPERTY OF POLARIS HINGE PTY. & GLASS HARDWARE AUSTRALIA PTY LTD. IT MUST NOT BE DISCLOSED, COPIED, LOANED IN WHOLE OR PART OR USED FOR ANY PURPOSE WITHOUT THE PERMISSION OF SHROUD AND/OR THEIR CLIENT.	
DRAWING SCALE: <b>DO NOT SCALE FROM THIS DRAWING</b>	UNLESS OTHERWISE STATED, ALL DIMENSIONS ARE IN mm. DIMENSIONS IN: mm
PROJECTION METHOD: <b>THIRD ANGLE</b>	SURFACE FINISH:

# 155 HINGE MODEL GLASS TO GLASS

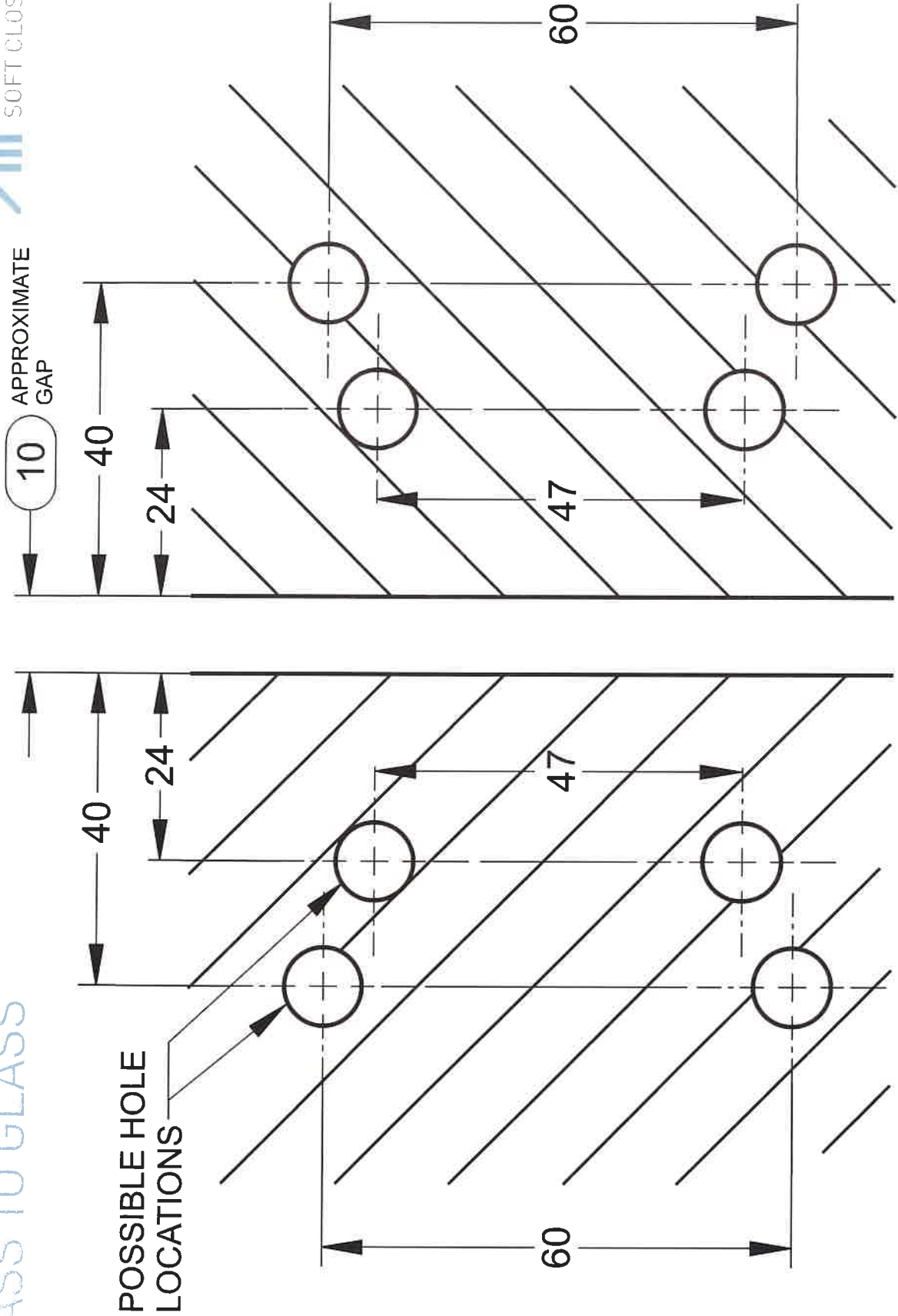

MATCH HOLES FOR RETRO FITMENT  
TOP AND BOTTOM HINGES HAVE TO BE SPACED MORE THAN 900mm APART  
(ALL DIMENSIONS IN MILLIMETERS)

INFORMATION SUPPLIED BY CUSTOMER

# LATCH GLASS TO GLASS 180°

TO ORDER SPECIFY:

- LAGG180P POLISHED FINISH
- LAGG180S BRUSHED FINISH
- LAGG180B BLACK FINISH

\*MAGNALOCK NOT INCLUDED

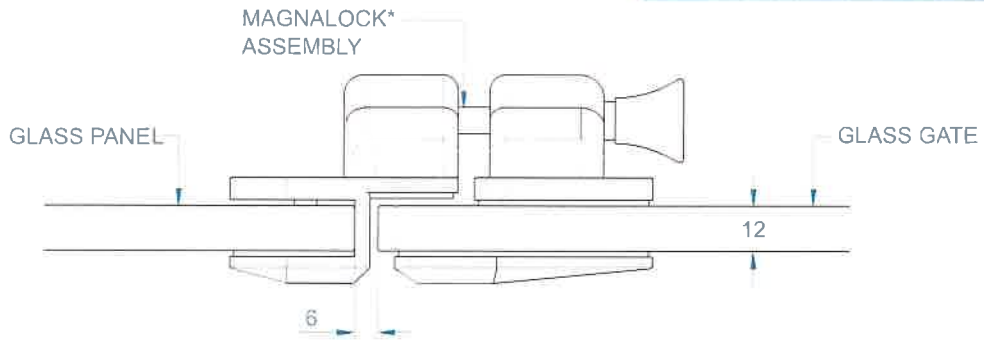

TOP VIEW

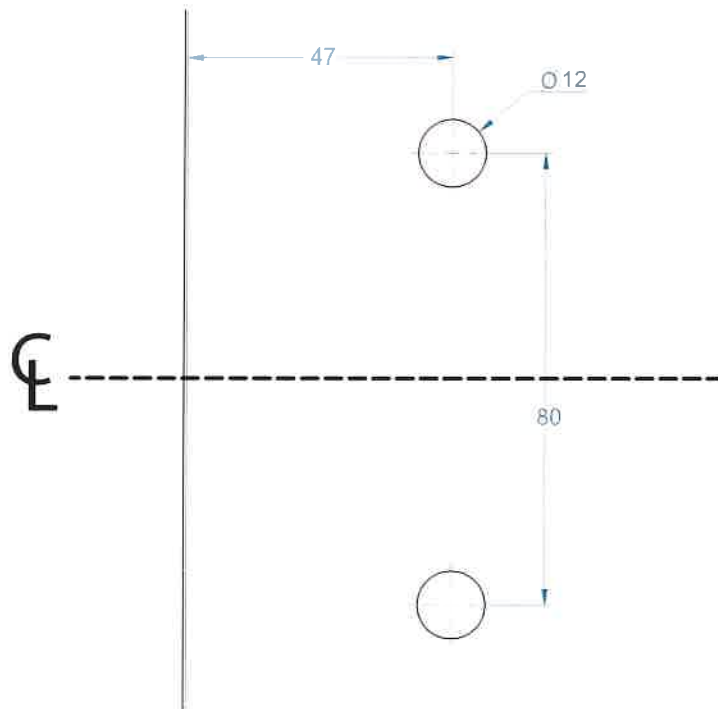

GLASS GATE HOLES

INFORMATION SUPPLIED BY CUSTOMER